

Indie series

Industrial grade Q-switched diode pumped Nd:YVO₄ laser



APPLICATIONS

- Marking
- Engraving
- Micromachining
- Ablation
- Drilling
- Cutting
- Structuring
- Trimming
- Mask repair
- Cleaning
- Your application is welcome...

FEATURES

- 15 W output power at 1064 nm
- High brilliance radiation
- Up to 100 kHz repetition rate
- Robust and sealed cavity
- Low operating costs
- Electro-optical Q-switching
- No first pulse problem
- Internal output power monitoring
- Internal/external triggering
- Processor control via USB/CAN/RS232
- Remote control via keypad
- No external water cooling

A diode pumped solid state Nd:YVO₄ lasers offer high output power of infra-red (1064 nm) radiation together with high repetition rate.

The **innovative** electro-optical Q-switch is a key technology for generation of the record short pulses between all high power nanosecond lasers.

High beam quality together with short pulse duration and high output power make Indie series laser to **high brilliance** source (tool) for processing of most engineering materials used in semiconductor and electronic industry.

Rugged body made of machined aluminum as well as **sealed cavity** ensures stable and reliable operation in diverse conditions of laboratory and factory working place.

The Indie series lasers are equipped with **intelligent control system**. Laser parameters are monitored continuously in order to ensure long term repeatability of performance and easy adaptation of the laser into high throughput material processing systems.

Short pulse duration, high repetition rate and robust design make these lasers an attractive tool for wide range of material processing applications, including metals, semiconductors, composites, dielectrics.

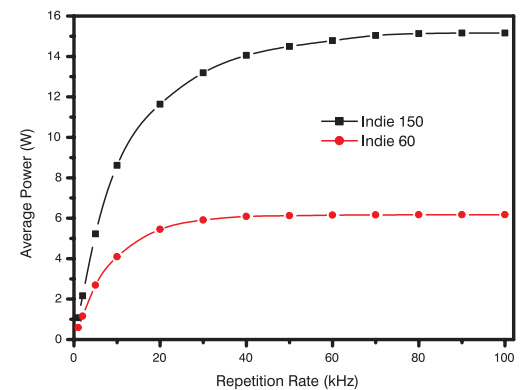
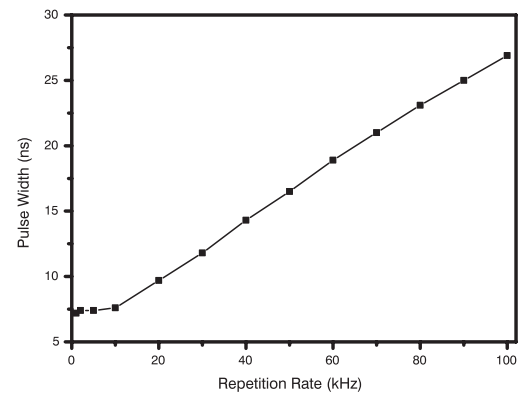

Specifications

Model	Indie 60	Indie 150
Output wavelength, nm	1064	
Output power, W	6	15
Pulse to Pulse energy stability, %	<1 (rms) at 20 kHz	
Power stability, %	± 2 over 8 hours	
Pulse duration, ns	6-28	
Repetition rate, kHz	Up to 100	
Beam diameter, mm	~ 0.7	
Beam profile	TEM ₀₀	
M ²	<1.5	
Beam divergence, mrad	<3.0	
Beam ellipticity	>0.9	
Polarization	Linear, horizontal >100:1	
Timing jitter, ns	<0.5 @ 1-30kHz	
Physical characteristics		
Laser head size (W x H x L), mm	164 x 72 x 265	294 x 88 x 259
Power supply/pump diode unit (W x H x L), mm	472 x 289 x 461	553 x 521 x 529
Umbilical length, m	2.8 (up to 10m)	
Operating requirements		
Ambient temperature, °C	18-27	
Relative humidity (non-condensing), %	10-80	
Voltage	100-240 VAC, single phase 50/60 Hz	
Power, kW	<0.25	<0.6

INDIE 150

Laser head outline drawing

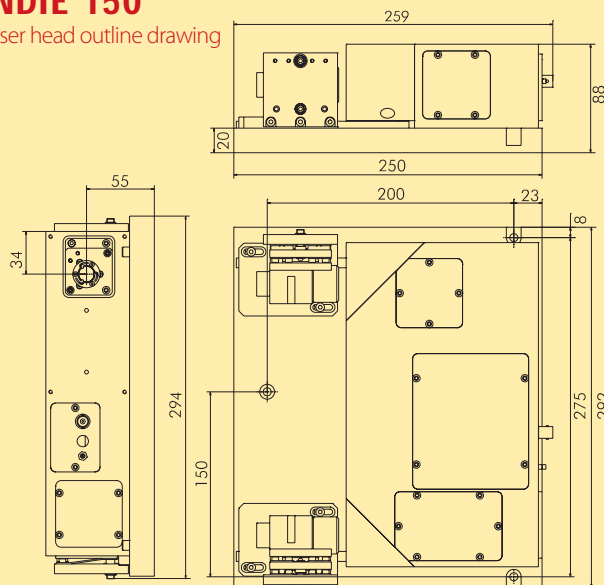

Power supply outline drawing

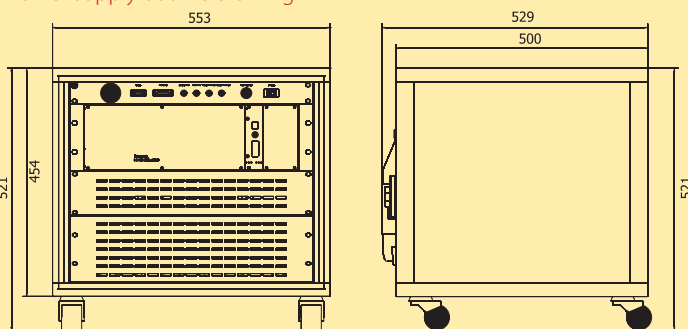

INDIE 60

Laser head outline drawing

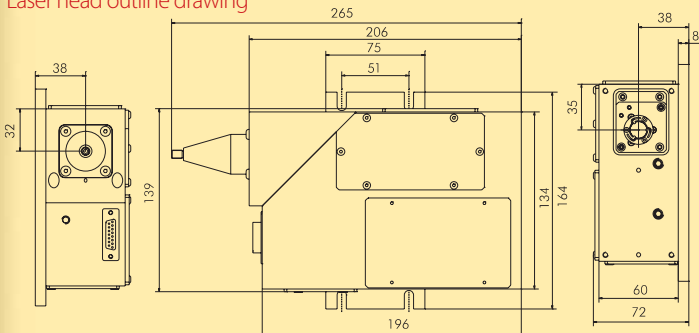

Power supply outline drawing

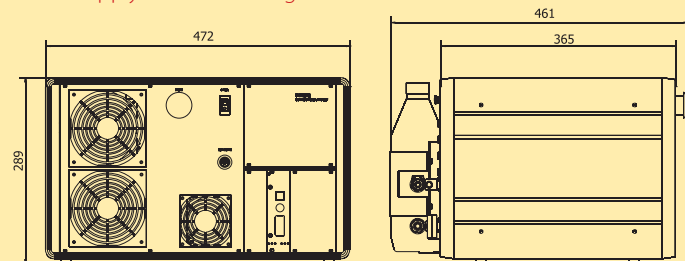

MACHINING SAMPLES



Marking of aluminium



Marking of stainless steel



Marking of brass



Marking of anodized aluminium



Cutting of copper foil



An EKSPA Group Company
Lasers and Laser Systems Div.
Savanoriu av. 231
02300 Vilnius – 53
Lithuania

Ph.: +370 5 2649629
Fax: +370 5 2641809
sales@ekspla.com
www.ekspla.com



EKSPLA distributor in United Kingdom:



Ingcris Laser Systems Ltd
14 Parris Road, Stokenchurch,
High Wycombe, Bucks. UK
Tel.: + 44 (0) 1494 482541
Fax: + 44 (0) 1494 482873
Email: sales@ingcris.com
www.ingcris.com